



# Skip Handlers

Innovative and efficient in every detail

| [meiller.com](https://meiller.com)

# Skip Handlers

Innovative and efficient in every detail

The MEILLER skip handler programme combines innovative solutions with a modern design. It is designed for daily and rugged operation.

Transport high payloads fast and safely thanks to the low tare weight of the vehicle superstructure. Handling and use are easy and practical – for economic and uncomplicated operation.

MEILLER skip handlers are designed for ultimate productivity – from the very first day and over their entire operating life. MEILLER stands for ultimate product quality and value retention.

## Ultimate quality through intelligent detailed solutions

MEILLER skip handlers are economic with a long service life. The good workmanship originates in state-of-the-art processing methods and profits from use of high-strength materials. The frame construction is extremely stable and well protected against corrosion.

The loading platform of the MEILLER skip handler comes without a vehicle-specific subframe. This results in a low tare weight and permits high payloads.

The high-quality MEILLER hydraulics ensure work operations are fast and delicate. This is complemented by precise and load-independent synchronisation of stabilising jacks and telescoping lifting arms – and this is with very low-noise operation.



*The MEILLER skip handler programme: from the general purpose single product right up to the customised system solution, here the AK16-MTG*

## MEILLER, the competent system supplier

MEILLER skip handlers are ideal for the entire range of chassis produced by all vehicle manufacturers.

We work closely together with truck manufacturers and optimally match MEILLER superstructures to the chassis. The MEILLER loading platform is designed to be vehicle-neutral. So we adapt your own product quickly and problem-free to every manufacturer.

Close collaboration with vehicle manufacturers results in short response times to new market demands.

## Your benefits

- **Economic operation through high reliability**
- **High working speed through easy operation and intelligent hydraulics**
- **Safe operation and transportation through certified solutions**
- **High payloads through low tare weight**
- **Maintenance-friendly and value preservation through high product quality**

## Designed for practical use.

With MEILLER skip handlers you transport skips and containers efficiently and reliably. They stand the test in the construction and waste management sectors and are made for harsh practical conditions.

- MEILLER skip handlers are strong and dirt-tolerant.
- The loading platform is easily accessible via steps.
- All work operations are simple and safe – even with gloves.
- When you have service needs your mobile MEILLER customer service will quickly and reliably assist you.

*Made for rugged use in the construction and waste management sectors: the MEILLER skip handler.*



## TECHNICAL DATA

Lifting forces	from 4 t to 17 t from road surface
for truck chassis	from 6 t to 33 t total weight
for containers/skips	DIN 30 735 DIN 30 720 Part 1 and 2 DIN 30 730-MAP-AKF Silo container (further containers on request)

# Skip handler programme

## AK4



## AK7



## AK10







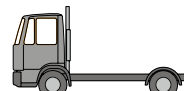
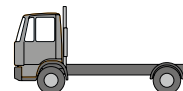

### TECHNICAL DATA

<p>Max. lifting force from road surface: 4,000 kg AK weight: 950 – 1,150 kg</p>	<p>Max. lifting force from road surface: 7,4000 kg AK weight: 2,000 – 2,150 kg</p>	<p>Max. lifting force from road surface: 11,000 kg AK weight: 2,070 – 2,000 kg</p>
---	--	--

### SUITABLE CHASSIS

<p>6.5 – 9 t</p> 	<p>9 – 12 t</p> 	<p>12 – 15 t</p> 
--	---	--

### CONTAINER SIZES

<p>up to 5 m<sup>3</sup> DIN 30 735</p> 	<p>DIN 30 720 Part 1</p> 	<p>DIN 30 720 Part 1</p> 	<p>DIN 30 720 Part 2</p> 
<p>DIN 30 720 Part 1</p>	<p>DIN 30 730-MAP-AKF</p>	<p>DIN 30 730-MAP-AKF</p> 	<p>DIN 30 730-MAP-AKF</p> 

### SUPPORTING ARM TYPES

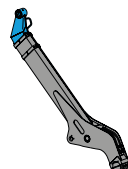
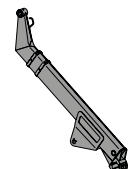
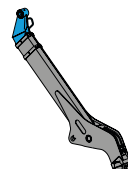
<p>TG lifting arm</p> 	<p>N lifting arm</p> 	<p>TG lifting arm</p> 
---	--	---

#### N lifting arm

- simple and sturdy
- Optimal for containers that often have the same size

#### T lifting arm

- for high tipping
- for all skip sizes

#### TG lifting arm

- for restricted space conditions
- optimum skip handling

# AK12-MTG



Skip handler	Related load in t from road surface	<b>Loading platform length</b> N = normal M = medium length L = long	<b>Supporting arm design</b> N = normal (rigid) T = telescopic Z = additional arm ZA = additional arm, turned	<b>Optional equipment</b> S = narrow version G = curved version
--------------	-------------------------------------	---	---	---

## AK12

## AK16



### TECHNICAL DATA

Max. lifting force  
from road surface: 14,000 kg  
AK weight: 2,770 – 3,010 kg

Max. lifting force  
from road surface: 18,000 kg  
AK weight: 3,120 – 4,060 kg

### SUITABLE CHASSIS

up to 20 t

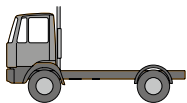

up to 33 t

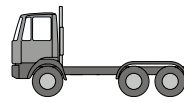

### CONTAINER SIZES

DIN 30 720 Part 1

DIN 30 720 Part 2

DIN 30 730-MAP-AKF

DIN 30 730-MAP-AKF

silos container \*)



### SUPPORTING ARM TYPES

N lifting arm

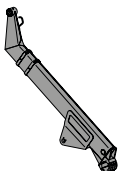

T lifting arm

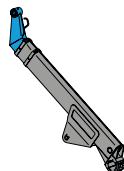

TG lifting arm

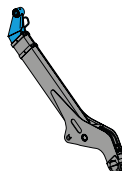

Z lifting arm

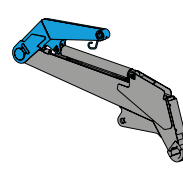

ZA lifting arm

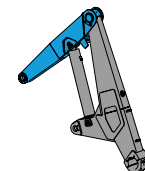

\*) with appropriate additional equipment

#### Z lifting arm

- for low height in travel position (e.g. for journeys through underpasses)

#### ZA lifting arm

- for low height in working position (e.g. picking up skips in halls)

# Container lock

Transport and load skips safely and professionally

MEILLER always provides you with the matching container lock: the modular concept makes different combinations possible. All MEILLER load securing modules are certified and can be operated with the radio control unit. With MEILLER skip handlers you can count on a reliable and appropriate container lock.

## Safe – with certificate

All MEILLER skip handlers meet the requirements for load securing pursuant to sections 22 and 23 StVO and section 30 StVZO in conjunction with VDI Directive 2700 and 2700 Sheet 17. (Certification through loading certificate issued by TÜV-Nord).



## Container lock modules

Choose from the different load securing modules. The combination of the BKE and CV modules gives ultimate safety: that is perfect load securing at the press of a button.



### Standard

Skid limit stops manually adjustable



### BKE = skip clamping mechanism

Hydraulically operating skid limit stops that secure sides of skips against slipping.

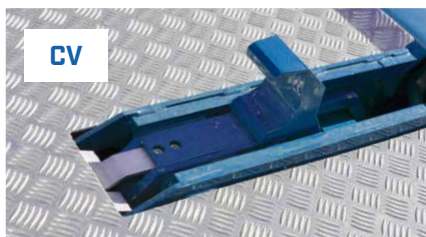

### CV = container locking mechanism

Hydraulically operating hooks that actively engage in the skip pivot bearings and effectively secure the skip to the front and rear.

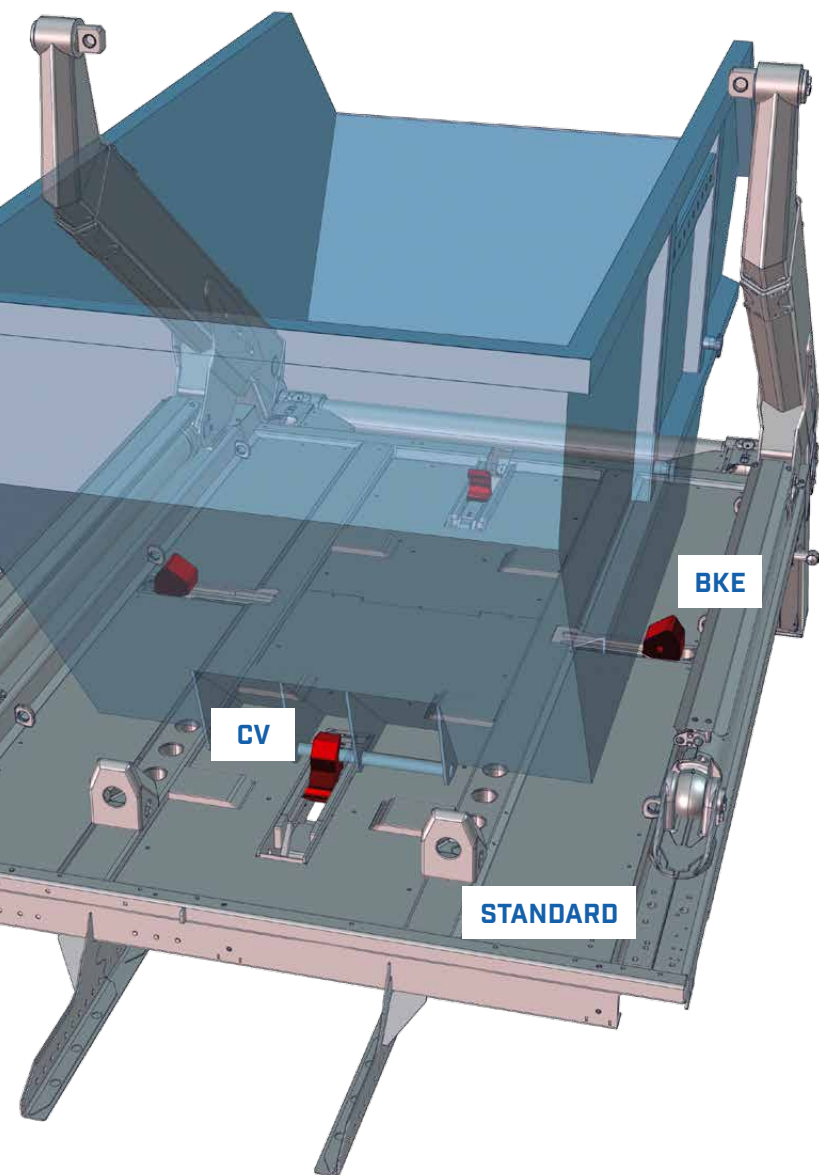

## Your benefits

- Certified and patented solutions.
- Fast and efficient securing through powerful hydraulics
- The right solution for everyone: load securing modules combinable
- Fast and easy to operate with radio control unit

### CONTAINER LOCK VARIANTS

	Standard	BKE module	CV module	Comfort	Comfort Plus
Side	manual	BKE	manual	BKE	BKE
Front	manual	manual	CV	manual	CV
At the back	skip support	skip support	CV	CV	CV



Protection for driver and cab: MEILLER front panel in different versions

### Container lock accessories

From MEILLER you can get everything you need for securing loads:

- lashing rings, safety and snap hooks
- Chain protection
- The front panel for the cab provides effective protection for the driver

# Operation

Simple and convenient for ultimate work safety

Operation of MEILLER skip handlers is easy and safe: all functions are logical, easy to understand and simple to use. It is even more convenient with the i.s.a.r.-control remote control: load containers from a safe distance and at a location that gives you the best visibility. With the pre-programmed sequence control processes it is easy to operate at the press of a button.



Always control your sequences fast and safely with the practical i.s.a.r.-control remote control, here the AK12-MT

## One button – many processes: very easy with sequence control

With the preprogrammed processes of the i.s.a.r.-control radio control unit you save time and avoid mistakes in the sequence of operating steps. Up to 30 seconds can be saved for each sequence. You start a complete process as easy as this: with a

button combination you activate a defined sequence of functions that are executed after each other. You always have full control and can intervene in the sequences at any time. With the thumb wheel you regulate the speed.



## Three different programme sequences are available:

1. Unlock container: fold down all tipping hooks, unlock the clamping mechanism and locking mechanism (if fitted)
2. Put down container: extend props, fold down all tipping hooks, unlock the container, swivel out the main arm

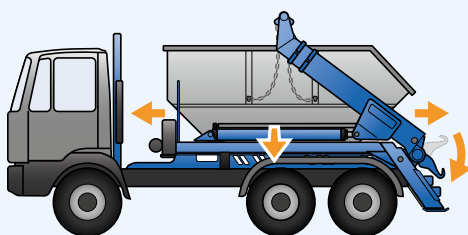

Unlocking a container

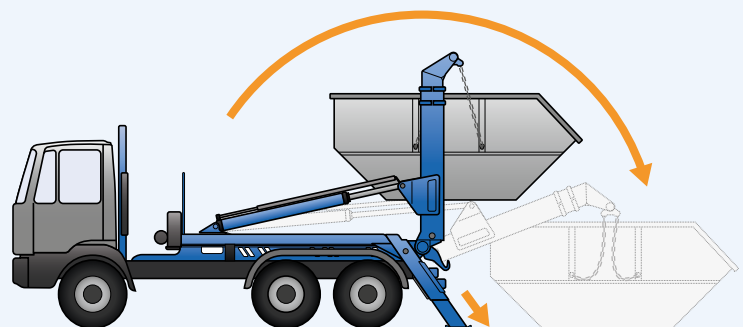

Putting down a container ...



### i.s.a.r.-control remote control

- One radio control unit for all functions
- Independent operating position, operator can take the best position
- Long radio range
- For rugged use:
  - Can also be operated with gloves
  - Illuminated buttons for night operation
  - Integrated antenna
  - Rubber surround
- Good handling:
  - Control elements arranged logically and clearly
  - Easy operation with thumb wheel
  - One-hand operation possible
- Low weight of only approx. 340 g
- Optimised power supply (Li-Ion battery without memory effect)
- Engine Start/Stop button centrally positioned
- Emergency stop button
- Belt clip and magnetic holder prevent loss

### Your benefits

- **Easy to understand radio control unit for all functions.**
- **Handling designed for rugged day and night use, can also be operated with gloves**
- **Sequence control for program mode ensures high work safety**
- **Control energy-efficient and time-saving**
- **Sophisticated and logical operating concept**
- **Sensitive control for optimum sequences**

3. Unlock container and make ready to travel: retract the telescope, lock the clamping mechanism as well as the hook in the rear. All tipping hooks are folded up, finally the stabilising jacks

are retracted – the driver can be confident that his skip handler is ready for driving on roads.

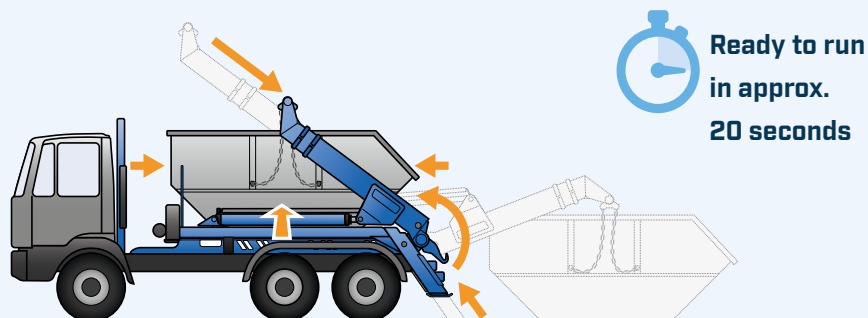

... lock and make ready to travel.

# Features for practical use

Practical solutions for everyday, rugged operation

## Economic ...

MEILLER protects you against risks, because our products remain economic over their entire operating life:

- Low maintenance requirements saves costs for spare parts and repairs.
- MEILLER product quality ensures good value retention and makes resales lucrative.
- Reliable MEILLER after-sales service and high spare-parts availability minimise down times.

MEILLER skip handlers guarantee safe operation thanks to many sophisticated solutions:

- LED rear lighting: you profit from additional road safety
- Camera systems: provide the best all-round view in the working area
- Overload controller: detects possible vehicle overloading. Overload protection reduces vehicle wear and tear and provides road safety
- Automatic level compensation
- Exact synchronisation of the rear prop gives high stability
- Underride protection: quickly removed for repairs
- Cab protective wall: gives effective protection to the driver
- Practical emergency control

## Adapt the chain length - easy and practical

Adapt your chain length with the MEILLER fastener: the practical chain suspension device at the top end of the telescopic arms makes it easy to shorten or lengthen the chain.



Optimum chain handling with the patented MEILLER M fastener.

## Safe MEILLER tipping hooks

With the sturdy tipping hooks you empty the container safely. The integrated safety catch protects the container against overturning and slipping out when tipping.



MEILLER triple tipping hook system



MEILLER control unit with integrated overload control display (standard with telescope equipment)

## Robust control unit:

MEILLER skip handlers have a practical control unit with emergency controller and protected installation of all controller components.

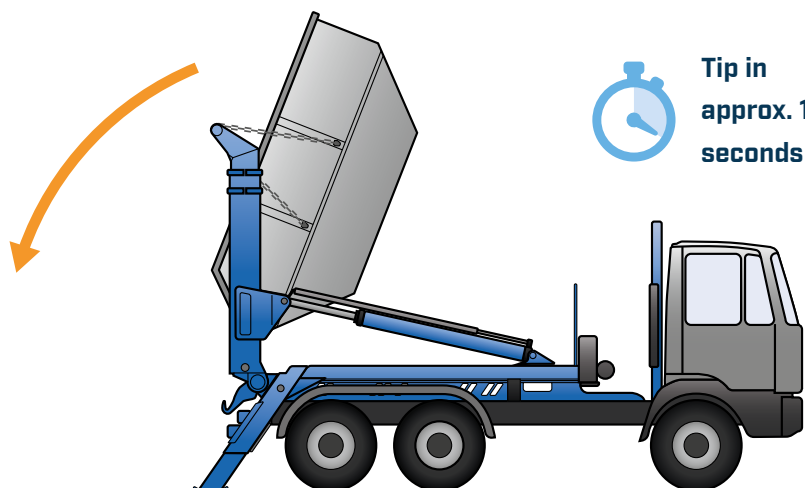

Tip in  
approx. 15  
seconds

 ORIGINAL  
MEILLER  
HYDRAULIK

### ... fast.

Intelligent MEILLER features increase the working speed:

- Load-dependent quick movement: accelerates putting down and tipping, and preserves the hydraulics. Operates over the entire stroke with empty containers. Quick movement is only switched on in a specific uncritical range for loaded containers.
- i.s.a.r.-control radio control unit: work quickly with the radio control unit. With the preprogrammed sequence control processes you save time.
- Powerful MEILLER hydraulics ensure a high working speed.

*Economic operation guaranteed: MEILLER skip handler AK16-MT with special equipment*



# Attachment parts and accessories

Extend as you want – the ideal vehicle for everyone

Optimise your MEILLER skip handler for your own purposes. With our accessories you design your daily work routine to be very safe and practical. The programme ranges from steps over storage options right up to camera systems.

## Lots of space for work aids and tools:

- Large storage box behind the cab, also suitable for bulky tools (shovels and brushes), with lockable lid.
- Storage boxes for small parts in the rear, with lockable lid
- Side toolbox
- Side extendible net boxes



Large storage box with lockable lid, fitted transverse behind the onboard frame.



Room used optimally: toolbox between the axles.

Standard BG-compliant steps.



## Climb onto the vehicle quickly and safely:

- Side steps are BG-compliant (German Employers' Liability Insurance Association)
- Rear steps on one or both sides, with retaining bracket on the arm, three offset steps



Steps at the rear.



## Lights with LED technology

Profit from additional road safety and improved visibility with MEILLER lights equipped with LED technology. A striking design is combined with a long service life and high efficiency. You also save time and costs as there is hardly ever a light failure.

### The MEILLER lights:

- LED rear lighting
- LED floodlight lamps
- LED warning around lamps
- Side MEILLER marker lamps



*Striking design: LED rear lighting*

## Make your daily work routine easier with further practical accessories:

- Side spare wheel carrier behind the cab
- Mud guards made from steel, aluminium or plastic
- Side MEILLER underride guard
- Camera systems
- Floor plates
- Wearing rails
- Trailer connecting plate
- Small parts such as hooks and eyelets, chains, signs, markers, fire extinguishers, brush and shovel holders, wheel chocks

## Telescopic equipment

With the telescopic equipment you obtain very long reaches of nearly 4.5 m. This, for instance, makes container handling easier when transferring with a trailer.



*MEILLER skip handler with telescopic equipment for long reaches.*

# The MEILLER company

Innovation from tradition for over 160 years

First-class quality and reliability characterise our products as well as creating the basis for the high satisfaction experienced by our customers. We systematically optimise the product development process chain to constantly increase our insistence on quality.

## Company

MEILLER is a synonym for innovative products and system solutions construction and waste management sectors. Our claim: to realise market-oriented innovations through the best technical solutions – with motivated employees, cutting-edge production processes and the contribution made by our employees.



*Every MEILLER employee stands for the high quality of all MEILLER products.*

## Product quality

MEILLER places special value on exemplary product quality and excellent value retention. This is why all components are designed for harsh operating conditions and a long service life. They excel through their good processing, reliability and low wear and tear.



## Fast service

Benefit from the expertise and competence of our experienced team. Our mobile after-sales service as well as our worldwide customer service points respond to you immediately whenever you require service.

Be assured, you're in good hands.

## Spare parts

Minimise down times through high availability and reliable delivery of spare parts. Our sophisticated logistics will supply you with original parts quickly to wherever they are needed.

Place your trust in the traditional quality of original MEILLER spare parts matched optimally to your MEILLER product.

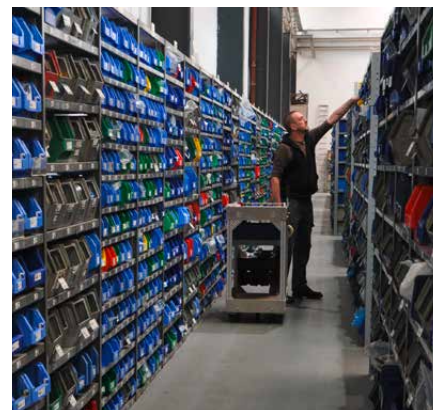

*Urgently needed original MEILLER spare parts come quickly to wherever they are needed.*



*To this day, many technical milestones and innovations from MEILLER continue to shape the sectors of construction, waste management and the commercial vehicle industry all over the world.*

# MEILLER global network

Full service from a single source

## Present worldwide

- MEILLER production sites / sales offices
- Service centers

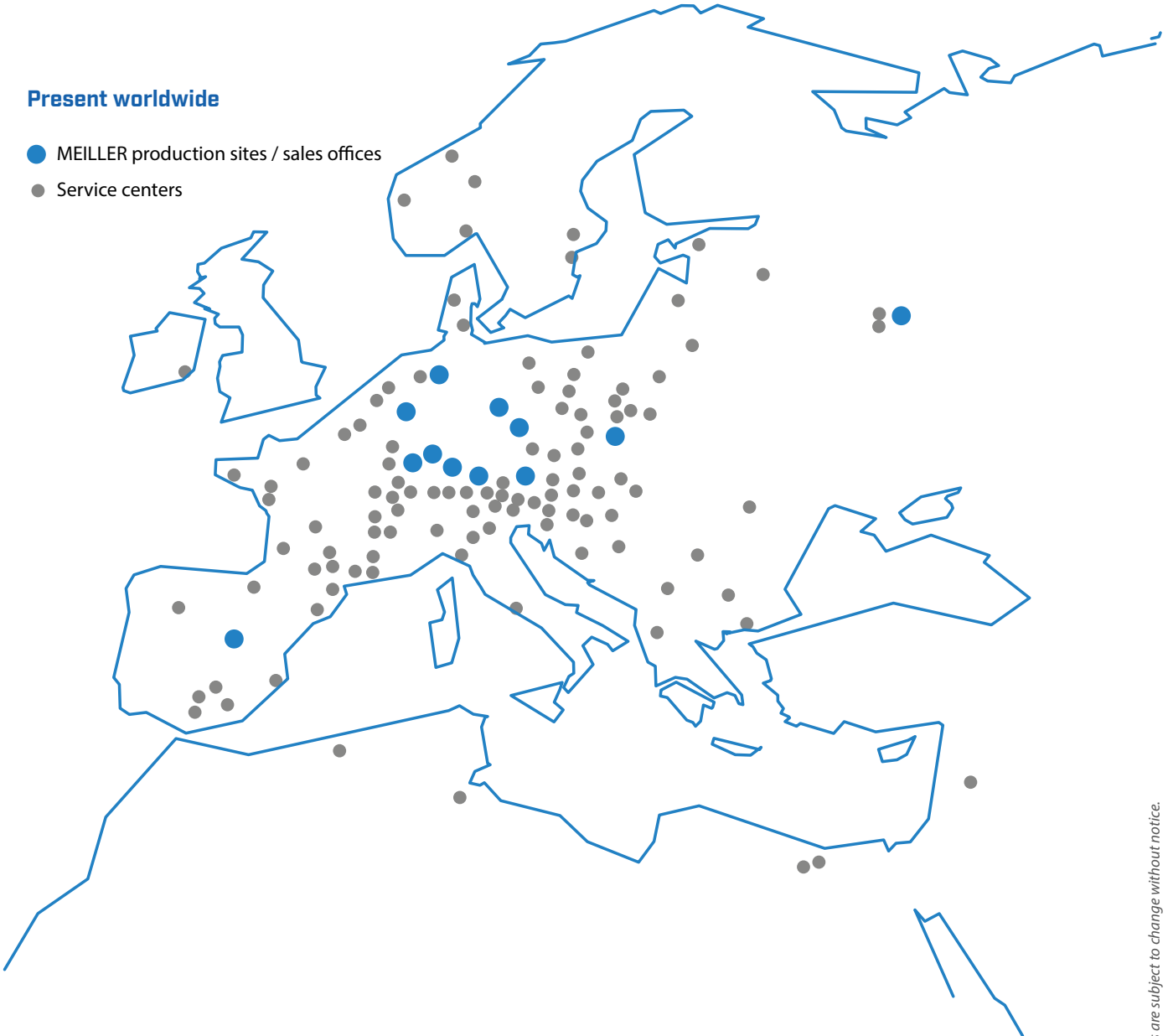

There is a MEILLER production site / sales office near you.  
Find the service centers closest to you by searching online at  
[meiller.com/service](http://meiller.com/service)

1609\_En-731-0518  
Technical specifications are subject to change without notice.  
Illustrations may show special equipment.