



# Three-way tipper

Innovative and efficient in every detail

| [meiller.com](https://meiller.com)

# Three-way tipper

Innovative and efficient in every detail

The MEILLER three-way tipper programme combines innovative solutions with a modern design. It is designed for daily and rugged operation. Transport high loads fast and safely thanks to the low tare weight of the vehicle superstructure. Handling and use are easy and practical – for economic and uncomplicated operation. MEILLER three-way tippers are designed for maximum productivity – from the first day on and throughout their entire working life. MEILLER stands for high product quality and value retention.

## Ultimate quality through intelligent detailed solutions

MEILLER three-way tippers are sturdy with a long service life due to the use of high-strength materials and the latest production processes. The frame construction is extremely stable and well protected against corrosion.

The low construction height simplifies the tipping of bulk material. The low centre of gravity ensures good road holding properties.

Your load is properly secured by means of the versatile lashing possibilities. MEILLER tarpaulin systems prevent falling of the load and protect sensitive transported goods against the effects of weather.

## Your benefits

- **Payload-optimised superstructure for high transport loads**
- **Sturdy design through high overload reserves**
- **Extremely high buckling and wear resistance**
- **Practical securing of the load due to versatile lashing possibilities**
- **Easy maintenance and value preservation through high product quality**

## From universal use to specific requirement

MEILLER three-way tippers can be used universally. The type 1 to type 9 (2-axle vehicle) series are suitable for all types of transport tasks: from use in communities, gardening and landscaping to usage on construction sites.

The 3 and 4-axle vehicle three-way tippers are used to transport bulk or piece goods, for driving in rugged construction-site operations or in road building. Your three-way tipper will meet your individual requirements.

*Made for universal use:  
MEILLER three-way tipper  
series type 3.*



*Series type 9*



**MEILLER hydraulics:  
Powerful. Durable. Efficient.**

With high loading volume, strongly dimensioned subframe and high performance hydraulics, the MEILLER three-way tipper is best equipped for heavy duty use.

Advantages of original MEILLER hydraulics:

- Our high pressure hydraulic system made of extremely high grade sturdy materials ensures minimum tare weight and best payload with optimum cylinder sizes.
- High-strength materials, nitrided surfaces and metallic guides make the system wear-free and dirt-tolerant
- MEILLER control valves and pumps give best cycle times and optimally designed oil circuits.



*The MEILLER hydraulic system is specially designed to meet the requirements in the construction industry.*



**Your benefits**

- High working speeds thanks to high-performance MEILLER hydraulics
- The ideal solution for any operating condition due to versatile side wall functions
- Robust and secure locks
- Payload-optimised design
- Practical handling for rough conditions

## Wide product range for all purposes

MEILLER provides a wide product range that meets your individual requirements. You will always find the right three-way tipper:

### Types 1 to 6L

For 2-axle chassis from 3.5 t to 13.5 t gross vehicle weight.

### Type 9

For 2-axle chassis from 14 t to 19 t gross vehicle weight.

### Types D316 to D428

For 3 or 4-axle chassis from 26 t to 41 t gross vehicle weight.



MEILLER three-way tipper type 3



MEILLER three-way tipper type 9



MEILLER three-way tipper type D421



A MEILLER three-way tipper type D316 in use.



## MEILLER, the competent system supplier

Strategic cooperation with all European commercial vehicle manufacturers enables us to achieve an optimum degree of harmonisation between the vehicle chassis and our superstructure.

A close exchange between MEILLER and truck manufacturers enables us to respond rapidly to new market requirements and underlies our competence as a system supplier.

# Three-way tipper product range



Select your individual solution from the broad MEILLER three-way tipper product range. At MEILLER, you receive "Everything from a single source": MEILLER steel construction, hydraulics, control engineering and tarpaulin systems are perfectly matched to each other.

## D428

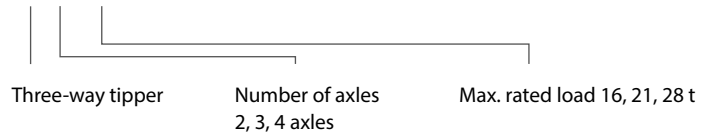

2-axle vehicle	Type	1	1.5	2	3	4	6L	9
	Rated load	1 800 kg	2 500 kg	3 700 kg	4 500 kg	6 500 k	7 800 kg	11 500 kg
	Suitable chassis with technical gross vehicle weight	3.5 t	4 - 5 t	5.1 - 6 t	7.49 - 8 t	9 - 10 t	11 - 13.5 t	14 - 19 t (22 t)
	Bridge length	2.6 m - 4.0 m			3.2 m - 4.2 m			3.4 m - 4.8 m
	Dropside height	0.35 m			0.4 m - 0.6 m			0.5 m - 0.8 m
	Bridge width	2 m - 2.2 m			2 m - 2.35 m			2.35 m - 2.42 m

### 3-axle vehicle



Type	D316	D321
Rated load	16 t	21 t
Suitable chassis with technical gross vehicle weight	26 t	33 t
Bridge length	4.6 m - 5.1 m	4.9 m - 5.1 m
Bridge width	2.38 m / 2.42 m	2.38 m
Dropside height	0.8 m - 1.1 m	1 m - 1.2 m

### 4-axle vehicle



Type	D421	D428
Rated load	21 t	28 t
Suitable chassis with technical gross vehicle weight	32 t	41 t
Bridge length	5.4 m - 6.2 m	
Bridge width	2.38 m / 2.42 m	2.38 m
Dropside height	0.9 m - 1.1 m	1 m - 1.2 m

# Three-way tipper types 1 to 2.5

For 2-axle chassis from 3.5 t to 7 t gross vehicle weight: The MEILLER three-way tipper types 1 to 2.5 are suitable for transport tasks in communities, gardening and landscaping.

## Features

### Practical side wall functions

- Silenced side wall bearing
- Drop type side walls
- Top-hinged and drop type tailgate
- Floor-level, retractable lashing lugs in the tipper body floor



MEILLER three-way tipper type 1.5

## Accessories for types 1 to 2.5

Optimise your MEILLER three-way tipper for your own special purposes.

- Protection for ball coupling
- Storage rack
- Long handle tool holder
- Stronger and more robust floor



Protection for ball coupling

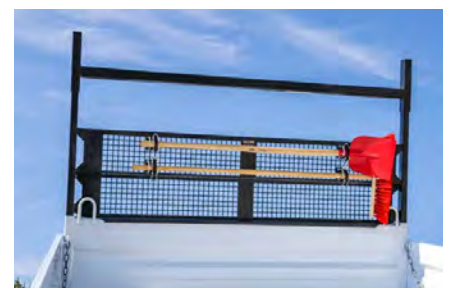

Rack with long handle tool holder

# Three-way tipper types 3 to 6L

For 2-axle chassis with a GVW of 7 to 14 t.

*MEILLER three-way tipper type 3*



## Features

### Practice-oriented equipment

- Noise-reduced wall hinges
- Bottom-hinged side walls
- Top- and bottom-hinged tailgate
- Floor-level, retractable lashing lugs in the tipper body floor

## Operation with loading crane

Load your transport goods with a loading crane onto your MEILLER three-way tipper. The subframe in the area of the loading crane is reinforced in preparation for loading crane operation. The hydraulic pump

capable of long endurance and the oil tank integrated in the subframe are designed for all common loading cranes. Switching from loading crane to tipper operation is quite simple using the change-over valve for tipper/crane operation.



*MEILLER three-way tipper with loading crane*

## Accessories for types 3 to 6L

Optimise your MEILLER three-way tipper for your own special purposes.

- Lashing eyelets in floor plate (types 4 - 6L)
- Aluminium side walls
- Storage rack
- Hydraulic connection for tipping trailer
- Protection for ball coupling
- Reinforced floor plate
- Long handle tool holder

# Three way tipper type 9

For 2-axle chassis from 14 t to 19 t gross vehicle weight.

## Transporting euro pallets

With the MEILLER three-way tipper type 9, you achieve an inside width of 2.42 m as standard, making it possible to transport euro pallets.

## Comfort package

You can use your three-way tipper even more flexibly with the comfort package.

The comfort package for the three-way tipper type 9 comprises:

- HB450 side walls (2.5 mm)
- Side walls top-hinged and drop type, with relief springs
- Robust, screwed corner posts with low-positioned locks (self-adjusting)
- Tailgate top-hinged and drop type, with automatic claw lock



MEILLER three-way tipper with comfort package and aluminium extension walls

For universal use: MEILLER three-way tipper type 9





## Aluminium heightening walls

Raise your side walls with the plug-in or screw-fitted elevation walls made of aluminium.

- Front and side walls
- Simple supplemental fitting without welding

## M-Jet side walls

Profit from the modern design with payload-optimised construction. The M-Jet side walls are robust and sturdy due to the membrane effect.



*MEILLER three-way tipper type 9 prepared for loading crane and aluminium extension walls*



*MEILLER three-way tipper type 9*

## Accessories for type 9

Optimise your MEILLER three-way tipper for your own special purposes.

- Pneumatic rear wall lock
- Hinged underride protection
- Aluminium side walls: Gain more payload with the side walls made of aluminium hollow profiles.

# Bordmatic

For convenient opening and closing of the left side wall

The Bordmatic is an hydraulic drop type (to almost 180°) side wall with high operating convenience. Open and close the left side wall from the tilting cab. The Bordmatic is ideal, e.g. in road building as a delivery chute for the central reservations.

### Advantages:

- The material cone is shifted further to the outside when tipping sideways: This protects the vehicle units.
- You can dispense the bulk material finer – thanks to the continuous hold position – than with a top-hinged side wall.
- The tipping of bulky material such as boulders is made easier by the unlimited discharge opening.

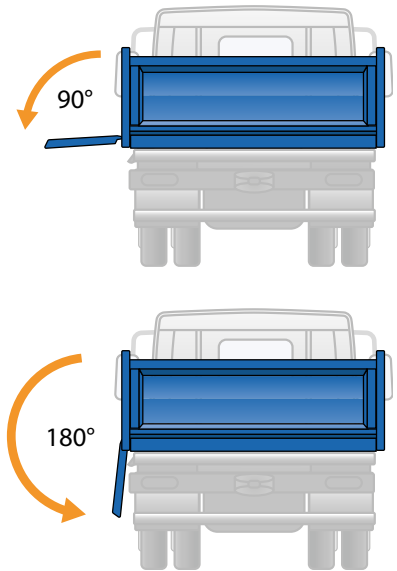

*Bordmatic with 90° bottom-hinged angle: The bulk material is unloaded far away from the vehicle.*

### SIDE WALL HEIGHTS

### NUMBER OF HYDRAULIC CYLINDERS

Type 9	600 - 800 mm	1
Types D316 - D321	800 - 900 mm	1
	1 000 - 1 100 mm	2
Types D421 - D428	900 - 1 000 mm	2
	1 100 mm	3

*Powerful MEILLER hydraulics at the Bordmatic side wall*



### MEILLER hydraulic system: Powerful. Persistent. Efficient.

- High-quality and robust system
- Dirt- and wear-resistant thanks to high-strength materials, nitrided and hard chrome-plated surfaces
- Optimised tipping valves and pumps ensure perfect cycles
- Sensitive motion control thanks to proportional technology even despite high loads
- Practically maintenance-free due to ideal oil circuits
- High availability of spare parts ensured by in-house manufacturing

# Features for practical use

Practical solutions for everyday, rugged operation

Securing the load is simple and safe with the MEILLER three-way tipper. MEILLER provides you with versatile lashing possibilities. Profit from the revised lashing concept based on DIN EN 12640. The bridge floor remains flat due to the retractable lashing eyelets preventing bulk material getting stuck.

## New lashing lugs for walls and floor

The newly developed and practical MEILLER solution for load-securing ensures a convenient and lawful transport of your loads.

### Numerous lashing equipment offer flexibility and practicability:

- Lashing rod under the tipper body

- Lashing lugs in the upper border of the side walls
- Floor-level, retractable lashing lugs in the tipper body floor
- Heavy-load lashing lugs secured by locking pins in the corners of the floor
- 2 swivelling lashing lugs in the front wall
- All MEILLER three-way tippers fulfill DIN CODE XL



Swivelling lashing lugs in the front wall (with 1 t lashing capacity) keep the load safe.



The lashing lugs in the corners of the floor (with 8 t lashing capacity) allow for variable securing possibilities.



The lashing lugs in the side walls (with 2 t lashing capacity) ensure flexible load securing.

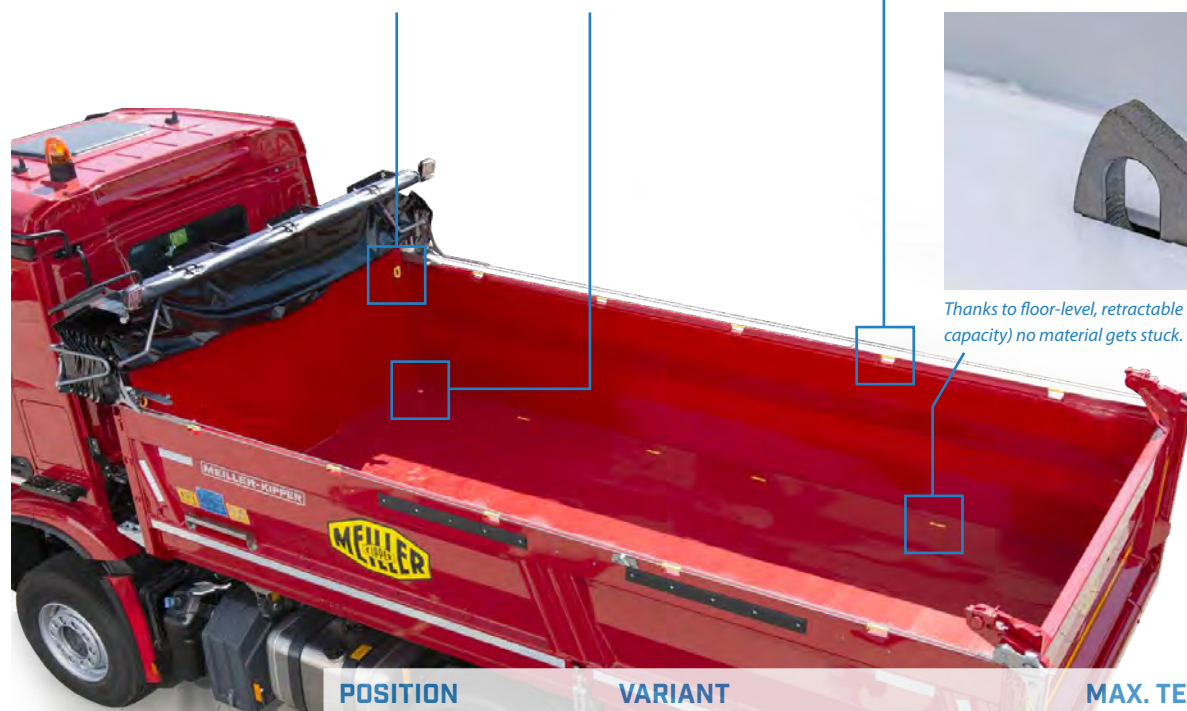

Thanks to floor-level, retractable lashing lugs (2 t lashing capacity) no material gets stuck.

Ladungssicherung nach DIN EN 12640, dabei bleibt der Brückenboden eben.

POSITION	VARIANT	MAX. TENSILE FORCE
Floor	Retractable lashing eyelets (from type 3)	2 t
Corners	Pluggable heavy load lashing eyelets (from type 9)	8 t (6 t with type 6L)
Front wall	Swivelling lashing eyelets (from type 9)	1 t
Under the tipper body	Additional railing for the outer lashings	1 t

# Three-way tipper types D316 to D428

## Wall variants

For 3 and 4-axle chassis from 26 t to 41 t gross vehicle weight. The MEILLER three-way tipper is suitable for all transport tasks in the construction industry.

### Practical: Flush tailgate

Your bulk material is tipped out completely: The tailgate is recessed between the fixed corner posts. Therefore, no bulk material can catch on the posts during sideways tipping.

### Suitable for the transport of pallets

Three-way tippers suitable for the transport of pallets (interior width 2,420 mm) enable the safe transport of Euro pallets.

This option includes higher steel quality and can also be combined with a Bordmatic side wall

### Side wall functions for every use

Choose your ideal solution from the different side wall variants.

#### Side wall

- Bordmatic: The left side wall opens and closes fully automatically with the Bordmatic – from the tilting cab or with the MEILLER i.s.a.r. control radio control unit.
- Top-hinged
- Top-hinged and drop type with relief springs

#### Tailgate

The tailgate function for the tailgate is always top-hinged. Use a scow-end or dosing devices for specific or defined tipping.

#### Aluminium side walls

Gain more payload with the side walls made of aluminium hollow profile.



Side wall top-hinged and drop type with relief springs.



Delivery chute, D421



Jet side walls

*Side walls made of 63 mm aluminium hollow profiles reduce the tare weight and increase the inside width to 2.42 m. It is thus possible to transport euro pallets.*



# Options and equipment



MEILLER sliding tarpaulin: The efficient tarpaulin system.



MEILLER side roller tarpaulin must be operated from below with a crank.

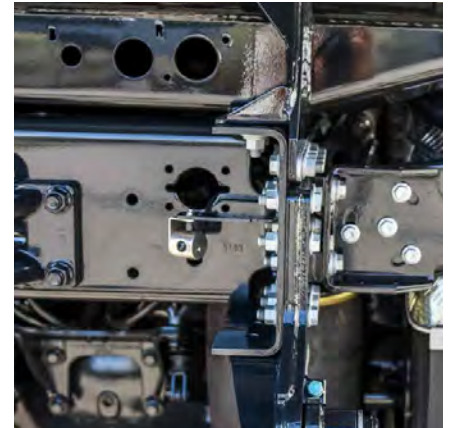

Rear area camera



MEILLER three-way tipper suitable for the transport of pallets with steel walls; i.s.a.r.-control remote is available as an option

## MEILLER i.s.a.r.-control radio control unit

With the MEILLER i.s.a.r.-control radio control unit you have full control: Tip from a safe distance and at a location that gives you the best visibility. The tipping, the Bordmatic, the hinging out and in of the underride protection, sliding tarpaulin and motor START/STOP are controlled with the MEILLER i.s.a.r. control radio control unit.



Loading area camera



## Accessories for 3 and 4-axle vehicles

Optimise your MEILLER three-way tipper for your own special purposes. The accessories are aimed at shaping your daily work routine to be safe and practical.

- MEILLER i.s.a.r.-control radio control unit
- Hinged underride protection (manually or hydraulically folding)
- Mud guard: Plastic (quarter or half shell) or aluminium (continuous chequered plate)
- Rear view camera
- Dosing device

# Tarpaulin systems

Ergonomic, efficient and lawful load securing.



MEILLER tarpaulin systems convince with functional and efficient solutions. They were designed for the use under rough conditions – from day 1 throughout their lifecycles. MEILLER stands for highest product quality and value preservation. Secure your loads compliant with legal regulations. The handling is easy as well as practice-oriented and ensures an economical and safe operation.

## In the field

Cover your transport materials appropriately with MEILLER tarpaulin systems. The tarpaulin not only protects loose materials from being blown off but also sensitive bulk material from weather conditions. On top of that fuel can be saved when covering the tipper body during transport.

## Everything from one source

MEILLER tarpaulin systems are designed to match all MEILLER products. Take advantage of an integrated and modular solution from one source. Three-way tippers, rear tippers, tipping semi-trailers or centre-axle trailers: all of them are prepared for the use of a MEILLER tarpaulin system.



Electric sliding tarpaulin



Lateral roll-up tarpaulin operated by crank from the ground

## You benefits

- Lawful load securing (compliant with VDI 2700)
- Everything from one source: MEILLER steel components, hydraulic systems, operation technology and tarpaulin systems
- Easy retrofitting



# The MEILLER company

Innovation from tradition for over 160 years

First-class quality and reliability characterise our products as well as creating the basis for the high satisfaction experienced by our customers. We systematically optimise the product development process chain to constantly increase our insistence on quality.



Every MEILLER employee stands for the high quality of all MEILLER products.

## Company

MEILLER is a synonym for innovative products and system solutions construction and waste management sectors. Our claim: to realise market-oriented innovations through the best technical solutions – with motivated employees, cutting-edge production processes and the contribution made by our employees.

## Product quality

MEILLER places special value on exemplary product quality and excellent value retention. This is why all components are designed for harsh operating conditions and a long service life. They excel through their good processing, reliability and low wear and tear.

## Spare parts

Minimise down times through high availability and reliable delivery of spare parts. Our sophisticated logistics will supply you with original parts quickly to wherever they are needed.

Place your trust in the traditional quality of original MEILLER spare parts matched optimally to your MEILLER product.



Urgently needed original MEILLER spare parts come quickly to wherever they are needed.



## Fast service

Benefit from the expertise and competence of our experienced team. Our mobile after-sales service as well as our worldwide customer service points respond to you immediately whenever you require service.

Be assured, you're in good hands.

To this day, many technical milestones and innovations from MEILLER continue to shape the sectors of construction and waste management.

# MEILLER in your vicinity

Full service from one source

## Worldwide presence

- MEILLER production sites/sales offices
- Service workshops

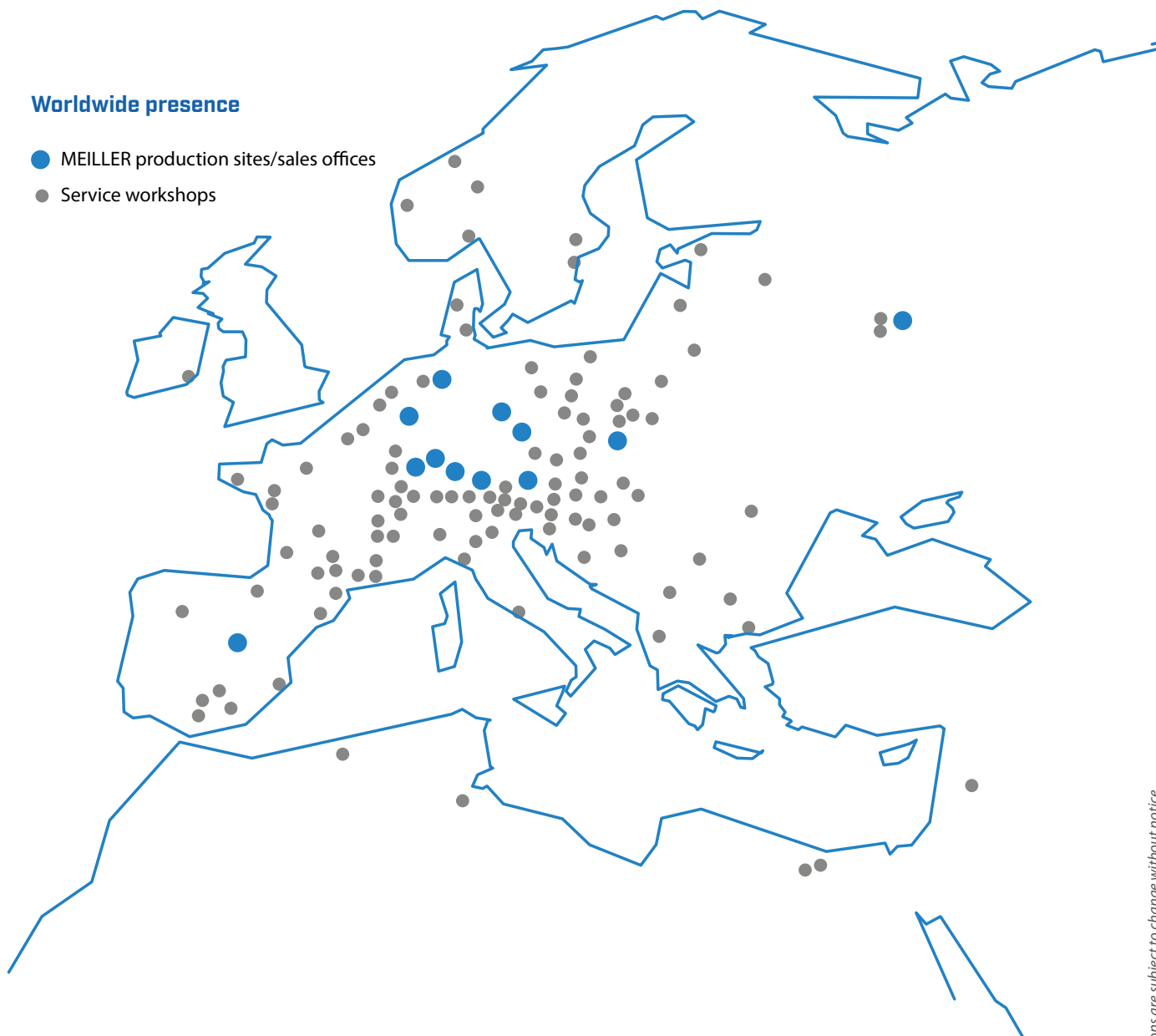

There is a MEILLER production site/sales office near you.

Find the nearest service workshops online under:

[meiller.com/service](http://meiller.com/service)

1632\_En-711-0918  
Technical specifications are subject to change without notice.  
Illustrations may show special equipment.

# F. X. MEILLER

Fahrzeug- und Maschinenfabrik - GmbH & Co KG · Ambossstraße 4 · 80997 Munich, Germany  
Telefon: +49 (89) 1487 - 0 · Telefax: +49 (89) 1487-1355 / 1595 · info@meiller.com · www.meiller.com